

# R Cylinder



## Specifications

Features																											
Type	ISO 6432 CETOP RP52P																										
Series	R																										
Configurations	R2 Double Acting, Single Rod R3 Single Acting, Single Rod, Spring Return R5 Double Acting, Single Rod, Magnetic Piston, Cushions R6 Double Acting, Single Rod, Magnetic Piston RDU 6 Double Acting, Double Rod, Magnetic Piston																										
Construction Materials																											
Barrel	Stainless Steel																										
End Caps	Aluminum, Anodized (10µ)																										
Piston Rod	Stainless Steel																										
Characteristics																											
Operating Temperature	Min. -5° F (-20°C) Max. +176°F (+80°C)																										
Operating Pressure	<table border="0"> <tr> <td></td> <td>Ø10</td> <td>Ø12-25</td> <td colspan="4"></td> </tr> <tr> <td>Min:</td> <td>22 PSI (1.5 bar)</td> <td>15 PSI (1 bar)</td> <td colspan="4"></td> </tr> <tr> <td>Max:</td> <td>145 PSI (10 bar)</td> <td>145 PSI (10 bar)</td> <td colspan="4"></td> </tr> </table>							Ø10	Ø12-25					Min:	22 PSI (1.5 bar)	15 PSI (1 bar)					Max:	145 PSI (10 bar)	145 PSI (10 bar)				
	Ø10	Ø12-25																									
Min:	22 PSI (1.5 bar)	15 PSI (1 bar)																									
Max:	145 PSI (10 bar)	145 PSI (10 bar)																									
Normal Operating Pressure	90 PSI (6 bar)																										
Lubrication	Pre-lubricated at factory. If additional lubrication is required use oil compatible for NBR seal and designed for use in pneumatic systems.																										
Media	Filtered and regulated compressed air																										
Installation	In any position																										
Weight	See chart with mounts																										
Stroke Length	Up to 320mm - Longer contact factory																										
Theoretical Forces	See Technical Information Sheet																										
Load Capacity	See Technical Information Sheet																										
Specifications																											
Piston Diameter		10	12	16	20	25																					
Port Sizes	Metric (G)	M5	M5	M5	G1/8	G1/8																					
Rod Diameter	mm	4	6	6	8	10																					
Cushion Lengths	mm				17	17																					

## Series R

Ø10mm - 25mm

ISO 6432

CETOP RP52P

**R 2: Double Acting, Single Rod**

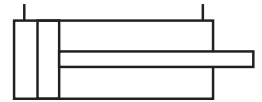

**R 3: Single Acting, Single Rod**

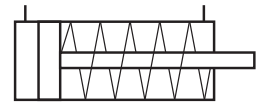

**R 5: Double Acting, Single Rod, Magnets, Cushions**

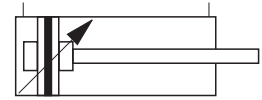

**R 6: Double Acting, Single Rod, Magnets**

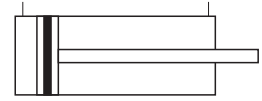

**RDU 6: Double Acting, Double Rod, Magnets**



### Features:

- Stainless Steel Rod
- Pre-Lubricated Design
- Magnetic Piston
- Adjustable Cushions

# R Cylinder



## Ordering Information

**Example:** R 5025/25  
ISO 6432  
Single Rod  
Double Acting, Magnets, Cushions  
25mm Bore  
25mm Stroke

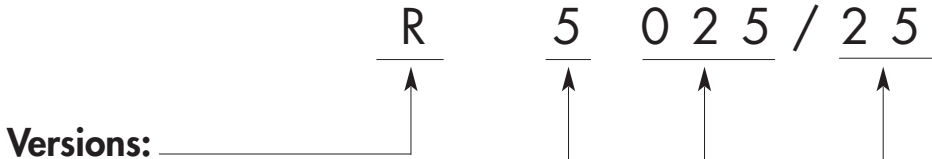

- R - Single Rod
- RDU - Double Rod

- Actuation:** \_\_\_\_\_
- 5 - Double Acting, Magnets, Cushions (Ø20 & 25)
  - 6 - Double Acting, Magnets
  - 2 - Double Acting
  - 3 - Single Acting, Magnets

- Stroke:**
- Ø10: any mm increment up to 100mm standard
  - Ø12 & 16: any mm increment up to 160mm standard
  - Ø20 & 25: any mm increment up to 320mm standard
  - Contact factory for special stroke lengths
  - Single acting stroke lengths of 10, 25 & 50mm

- Bore:**
- 010 - 10mm (nom. 7/16")
  - 012 - 12mm (nom. 1/2")
  - 016 - 16mm (nom. 3/4")
  - 020 - 20mm (nom. 7/8")
  - 025 - 25mm (nom. 1")

**Proximity Sensors/Brackets: See Page 73**

# R Cylinder



## Dimensional Data

### R2, R3, R5, R6 Ø10-25mm

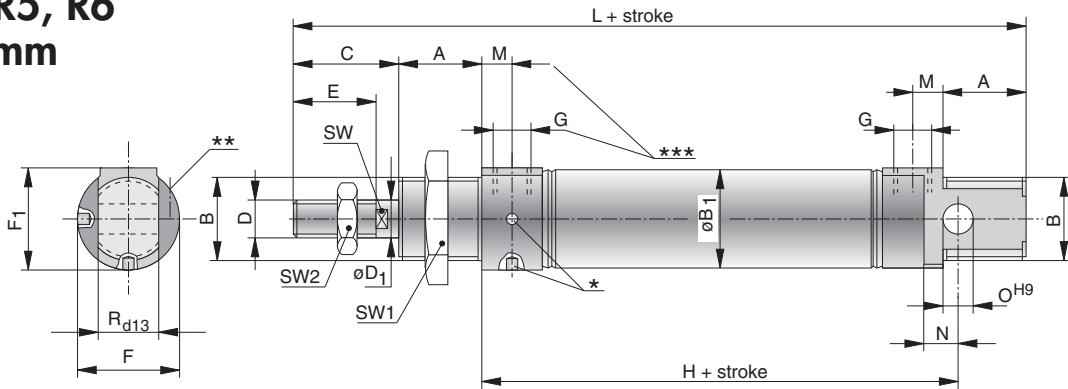

### RDU 6 Ø12-25mm

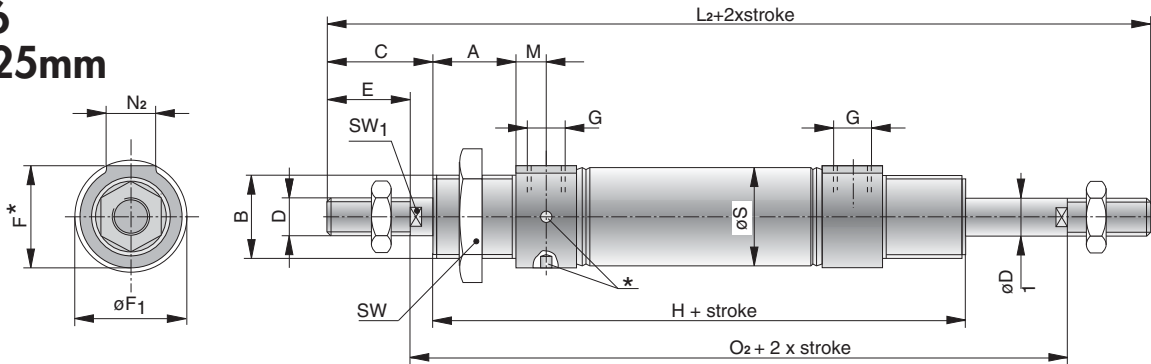

- \* Holes for "C" Spanner Wrench
- \*\* Location of Adjustable Cushion, R5020 & R5025 Only
- \*\*\* Omit Dimensions "G" and "M" for Series R3 Cylinders

Bore Ø	A	B	B <sub>1</sub>	C	D	Ø D <sub>1</sub>	E	F	F <sub>1</sub> hex	G	H + stroke	H <sub>2</sub> + stroke
10	0.47 12	7/16 • 20 M12 x 1.25	0.44 11.3	0.63 16	6 • 32 M4	0.16 4	0.47 12	0.59 15	0.59 15	10 • 32 M5	1.89 48	- -
12	0.67 17	M16 x 1.5	0.52 13.3	0.83 21	M6	0.24 6	0.63 16	0.79 20	0.79 20	M5	2.09 53	3.23 82
16	0.67 17	5/8 • 18 M16 x 1.5	0.68 17.3	0.83 21	10 • 32 M6	0.24 6	0.63 16	0.79 20	0.79 20	10 • 32 M5	2.36 60	3.54 90
20	0.79 20	M22 x 1.5	0.83 21.3	0.94 24	M8	0.30 8	0.79 20	1.06 27	1.06 27	G1/8	2.80 71	4.25 108
25	0.87 22	7/8 • 14 M22 x 1.5	1.04 26.5	1.10 28	3/8 • 24 M10 x 1.25	0.39 10	0.87 22	1.06 27	1.06 27	1/8 NPTF G1/8	2.99 76	4.45 113
Bore Ø	L + stroke	L <sub>2</sub> +2X stroke	M	N	N <sub>2</sub>	Ø O <sub>H9</sub>	O <sub>2</sub> +2X stroke	R <sub>d13</sub>	ØS	SW	SW <sub>1</sub>	SW <sub>2</sub>
10	3.39 86		0.22 5.5	0.24 6	- -	0.16 4	- -	0.31 8	- -	0.12 3	0.67 17	- -
12	4.09 104	4.88 124	0.22 5.5	0.35 9	0.37 9.5	0.24 6	3.62 92	0.47 12	0.52 13.3	0.20 5	0.87 22	10
16	4.37 111	5.20 132	0.22 5.5	0.35 9	0.37 9.5	0.24 6	3.94 100	0.47 12	0.68 17.3	0.20 5	0.87 22	10
20	5.20 132	6.14 156	0.33 8.5	0.47 12	0.57 14.5	0.31 8	4.57 116	0.63 16	0.84 21.3	0.28 7	1.06 27	13
25	5.55 141	6.65 169	0.33 8.5	0.47 12	0.57 14.5	0.31 8	4.92 125	0.63 16	1.04 26.5	0.35 9	1.06 27	17

# R Cylinder



## Cylinder Mounts

### Foot Mount- Type RA

- RA1- 1 Bracket with Mounting Nut
- RA2- 2 Brackets with Mounting Nuts

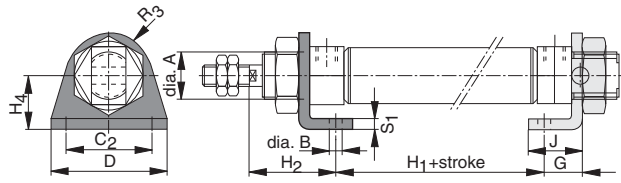

### Rear Clevis- Type RB

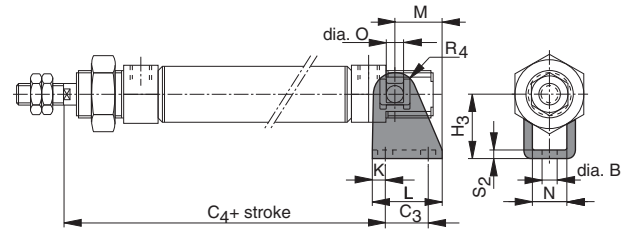

### Front or Rear Flange- Type RC

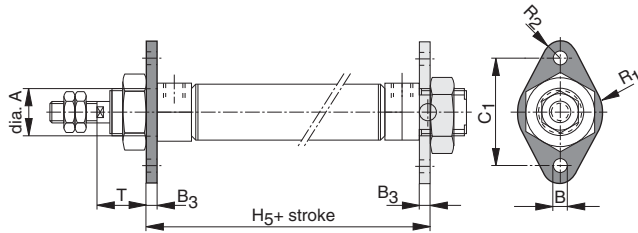

**Ordering Information:**  
See ROV Series Cylinder on Page 14

Bore Ø	A	B	B <sub>3</sub>	C <sub>1</sub>	C <sub>2</sub>	C <sub>3</sub>	C <sub>4+</sub>	D	G	H <sub>1</sub> + stroke	H <sub>2</sub>	H <sub>3</sub>	H <sub>4</sub>	H <sub>5</sub> stroke
10	0.47 12	0.18 4.5	0.12 3	1.18 30	0.98 25	0.49 12.5	2.56 65	1.38 35	0.43 11	1.14 29	0.94 24	0.94 24	0.63 16	2.52 64
12	0.63 16	0.22 5.5	0.16 4	1.57 40	1.26 32	0.59 15	2.87 73	1.65 42	0.55 14	1.02 26	1.26 32	1.06 27	0.79 20	2.83 72
16	0.63 16	0.22 5.5	0.16 4	1.57 40	1.26 32	0.59 15	3.15 80	1.65 42	0.55 14	1.30 33	1.26 32	1.06 27	0.79 20	3.11 79
20	0.87 22	0.26 6.6	0.20 5	1.97 50	1.57 40	0.79 20	3.58 91	2.13 54	0.67 17	1.69 43	1.42 36	1.18 30	0.98 25	2.83 97
25	0.87 22	0.26 6.6	0.20 5	1.97 50	1.57 40	0.79 20	3.94 100	2.13 54	0.67 17	1.89 48	1.57 40	1.18 30	0.98 25	4.13 105
Bore Ø	J	K	L	M	N	O	R <sub>1</sub>	R <sub>2</sub>	R <sub>3</sub>	R <sub>4</sub>	S <sub>1</sub>	S <sub>2</sub>	T	
10	0.63 16	0.26 6.5	0.91 23	0.71 18	0.32 8.1	0.16 4	0.49 12.5	0.20 5	0.39 10	0.20 5	0.12 3	0.10 2.5	0.51 13	
12	0.79 20	0.20 5	0.98 25	0.71 18	0.48 12.1	0.24 6	0.59 15	0.26 6.5	0.47 12	0.28 7	0.16 4	0.12 3	0.71 18	
16	0.79 20	0.20 5	0.98 25	0.71 18	0.48 12.1	0.24 6	0.59 15	0.26 6.5	0.47 12	0.28 7	0.16 4	0.12 3	0.71 18	
20	0.98 25	0.24 6	1.26 32	0.87 22	0.63 16.1	0.31 8	0.79 20	0.31 8	0.79 20	0.39 10	0.20 5	0.16 4	0.91 19	
25	0.98 25	0.24 6	1.26 32	0.87 22	0.63 16.1	0.31 8	0.79 20	0.31 8	0.79 20	0.39 10	0.20 5	0.16 4	0.91 23	

**Proximity Sensors/Brackets: See Page 73**

# R Cylinder



## Cylinder Accessories

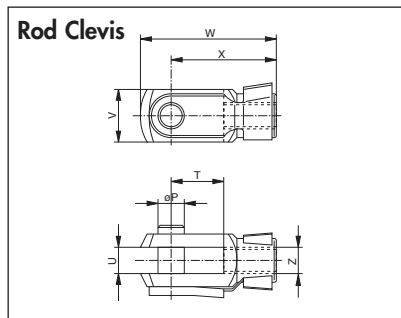

Order Instructions									
Order #	Bore Ø	ØP	T	U	V	W	X	Z	Weight (lbs.)(kg)
KZ 1413	8,10	0.16	0.31	0.16	0.31	0.87	0.63		0.02
		4	8	4	8	22	16	M4	0.008
KY 6132	12,16	0.24	0.47	0.24	0.47	1.22	0.94		0.04
		6	12	6	12	31	24	M6	0.016
KY 6133	20	0.31	0.63	0.31	0.63	1.65	1.26		0.08
		8	16	8	16	42	32	M8	0.038
KY 6135	25	0.39	0.79	0.39	0.79	2.05	1.57		0.18
		10	20	10	20	52	40	M10 x1.25	0.08

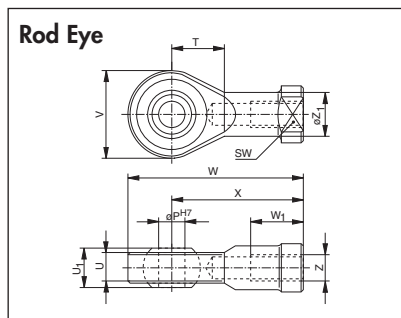

Order Instructions													
Order #	Bore Ø	Øp <sup>H7</sup>	T	U	U1	V	W	W <sub>1</sub>	X	Z	ØZ <sub>1</sub>	SW	Weight (lbs.)(kg)
KX 6023	8,10	0.20	0.35	0.24	0.31	0.63	1.38	0.47	1.06		0.35	0.31	0.05
		5	9	6	8	16	35	12	27	M4	9	8	0.021
KY 6144	12,16	0.24	0.43	0.27	0.35	0.79	1.57	0.47	1.18		0.39	0.43	0.06
		6	11	6.75	9	20	40	12	30	M6	10	11	0.025
KY 6145	20	0.31	0.51	0.35	0.47	0.94	1.89	0.63	1.42		0.49	0.55	0.09
		8	13	9	12	24	48	16	36	M8	12.5	14	0.043
KY 6147	25	0.39	0.59	0.41	0.55	1.10	2.24	0.79	1.69		0.59	0.67	0.16
		10	15	10.5	14	28	57	20	43	M10 x1.25	15	17	0.072

### Rod Alignment Coupling

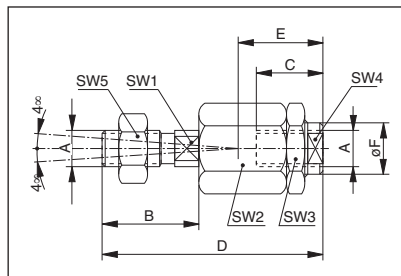

### Angular Compensation

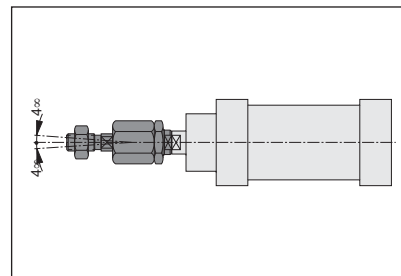

### Radial Compensation for the Center Axis

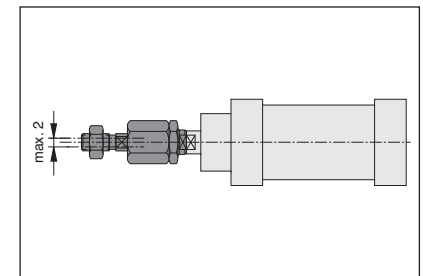

Order Instructions													
Order #	Bore Ø	A	B	C	D	E	ØF	SW <sub>1</sub>	SW <sub>2</sub>	SW <sub>3</sub>	SW <sub>4</sub>	SW <sub>5</sub>	Weight (lbs.)(kg)
KY 1152	8,10	M4	0.31	0.55	1.34	0.79	0.47	0.12	0.47	0.47	0.47	0.28	0.04
			8	14	34	20	12	3	12	12	12	7	0.018
KY 1126	12,16	M6	0.47	0.43	1.42	0.55	0.33	0.20	0.51	0.51	0.28	0.39	0.05
			12	11	36	14	8.5	5	13	13	7	10	0.021
KY 1127	20	M8	0.51	0.55	1.81	0.79	0.49	0.28	0.67	0.67	0.39	0.51	0.11
			13	14	46	20	12.5	7	17	17	10	13	0.049
KY 1129	25	M10x1.25	0.79	0.91	2.76	1.22	0.85	0.47	1.18	1.18	0.75	0.67	0.48
			20	23	70	31	21.5	12	30	30	19	17	0.218

Proximity Sensors/Brackets: See Page 73

# ROV Oval Bore Cylinder



## Specifications

Features							
Type	Oval Bore (ISO 6432)						
Series	ROV						
Configurations	ROV 6 Double Acting, Single Rod, Magnetic Piston ROV 7 Single Acting, Single Rod, Magnetic Piston, Spring Return ROVD 6 Double Acting, Double Rod, Magnetic Piston ROVDG Double Acting, Double Rod, Magnetic Piston, Hollow Rod						
Construction Materials							
Barrel	Stainless Steel						
End Caps	Aluminum, Anodized (10µ)						
Piston Rod	Stainless Steel						
Rod Bearing	Teflon Impregnated Bronze						
Piston	Urethane						
Seals	Urethane						
Cushion Needle	Brass						
Characteristics							
Operating Temperature	Min. 14° F (-10°C) Max. +176°F (+70°C)						
Operating Pressure	Min. Double Acting - 15 PSI (1 bar), Single Acting - 30 PSI (2 bar) Max. 145 PSI (10 bar)						
Normal Operating Pressure	90 PSI (6 bar)						
Lubrication	Pre-lubricated at factory. If additional lubrication is required use oil compatible with NBR seals and designed for use in pneumatic systems.						
Media	Filtered and Regulated Compressed Air						
Installation	In any Position						
Weight	See Chart - Page 15						
Stroke Length	Varies by Bore Size						
Theoretical Forces	See Technical Information Sheet						
Load Capacity	See Technical Information Sheet						
Specifications							
Piston Diameter		8	10	12	16	20	25
Port Sizes	Metric (G)	M5	M5	M5	M5	G 1/8	G 1/8
Rod Diameter	mm	4	4	6	6	8	10
Cushion Lengths	mm	--	--	--	--	14	16

## Series ROV

Ø8mm - 25mm

Oval Bore (ISO 6432)

**ROV 6: Double Acting, Single Rod, Magnets**

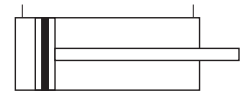

**ROV 7: Single Acting, Single Rod, Magnets**

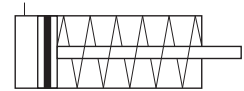

**ROVD 6: Double Acting, Double Rod, Magnets**



**ROVDG: Double Acting, Double Rod, Magnets, Hollow Rod**

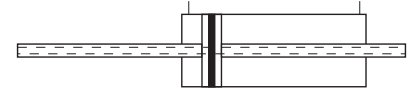

### Features:

**Stainless Steel Rod**  
**Pre-Lubricated Design**  
**Magnetic Piston**  
**Adjustable Cushions**  
**(Ø20 & 25 only)**  
**Double Hollow Rod**

# ROV Oval Bore Cylinder



## Ordering Information

**Example:** ROV 6020/50  
Oval Piston  
Single Rod  
Double Acting, Magnets  
20mm Bore  
50mm Stroke

ROV 6020 / 50

### Versions:

- ROV - Single Rod
- ROVD - Double Rod
- ROVDG - Double Hollow Rod

### Actuation:

- 5 - Double Acting, Magnets, Cushions
- 6 - Double Acting, Magnets
- 7 - Single Acting, Magnets

**Proximity Sensors/Brackets: See Page 73**

### Stroke:

- MM: (standard)
- Ø8 & 10: any mm increment up to 100mm standard
  - Ø12 & 16: any mm increment up to 300mm standard
  - Ø20 & 25: any mm increment up to 500mm standard
  - Contact factory for special stroke lengths
  - Single acting stroke lengths of 10, 25 & 50mm

### Bore:

- 008 - 8mm (nom. 5/16")
- 010 - 10mm (nom. 7/16")
- 012 - 12mm (nom. 1/2")
- 016 - 16mm (nom. 3/4")
- 020 - 20mm (nom. 7/8")
- 025 - 25mm (nom. 1")

# ROV Oval Bore Cylinder



## Cylinder Mounts

Weights		8mm		10mm		Bore Ø 12mm		16mm		20mm		25mm	
		*1	*2	1	2	1	2	1	2	1	2	1	2
Basic Cylinder	lbs.	.178		.198	.088	0.33	.132	.374	.176	.847	.286	.847	.286
	kg	0.081		0.090	0.040	0.150	0.060	0.170	0.080	0.385	0.130	0.385	0.130
Type RA (1 bracket)	lbs.	.048		.048		.095		.095		0.22		0.22	
	kg	0.022		0.022		0.043		0.043		0.100		0.100	
Type RC	lbs.	.029		.029		.062		.062		0.11		0.11	
	kg	0.013		0.013		0.028		0.028		0.050		0.050	
Type RB	lbs.	.051		.051		.079		.079		.176		.176	
	kg	0.023		0.023		0.036		0.036		0.080		0.080	

\*1 = Weight for cylinder with (100 mm) stroke

\*2 = Weight for every additional (100 mm) stroke length

Body Mounts		8mm	10mm	Bore Ø 12mm	16mm	20mm	25mm
<b>Foot Mount (single pc.)</b>							
Type: RA1-	Metric	KX 9271	KX 9271	KK 26.302	KK 26.302	KK 28.302	KK 28.302
<b>Foot Mount (Set)</b>							
Type: RA2-	Metric	PD 31522	PD 31522	PD 25771	PD 25771	PD 25772	PD 25772
<b>Rear Clevis</b>							
Type: RB-	Metric	KZ 1412	KZ 1412	KZ 1419	KZ 1419	KZ 1420	KZ 1420
<b>Front or Rear Flange</b>							
Type: RC	Metric	KX 9272	KX 9272	KK 26.305	KK 26.305	KK 28.305	KK 28.305

**Dimensional Information: See R Series Cylinder on Page 10.**

Rod Accessories		8mm	10mm	Bore Ø 12mm	16mm	20mm	25mm
Rod Nut	Metric	ZP 3838	ZP 3838	ZP 1730	ZP 1730	ZP 2128	ZP 1810
Nose Nut	Metric	ZP 4077	ZP 4077	ZP 4078	ZP 4078	PD 35855	PD 35855
Rod Clevis	Metric	KZ 1413	KZ 1413	KY 6132	KY 6132	KY 6133	KY 6135
Rod Eye	Metric	KX 6023	KX 6023	KY 6144	KY 6144	KY 6145	KY 6147
Rod Alignment Coupling	Metric	KY 1152	KY 1152	KY 1126	KY 1126	KY 1127	KY 1129

**Dimensional Information: See R Series Cylinder on Page 11**

**Proximity Sensors/Brackets: See Page 73**

# ROV Oval Bore Cylinder



## Dimensional Data

### ROV Ø8-25mm

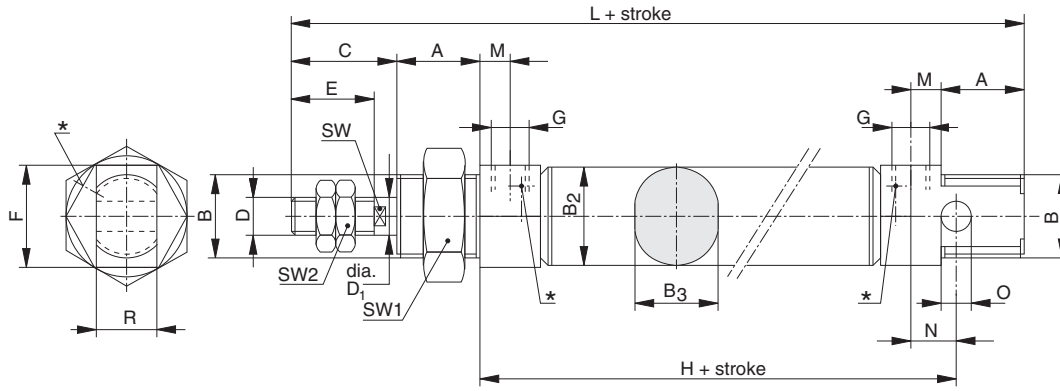

- \* Port is omitted on the Spring Return version
- \*\* Adjustable Cushion Location. Bore 20 and 25 ONLY

### ROVD Ø8-25mm

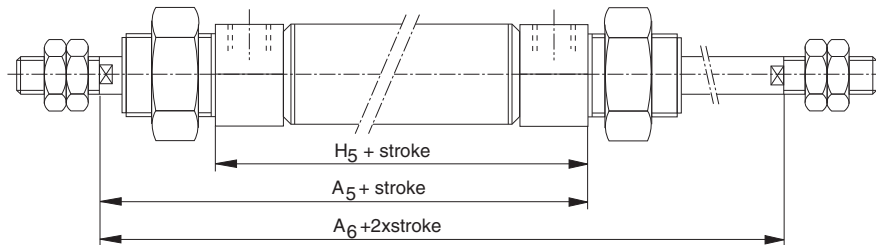

See ROV drawing for balance of dimensions

### ROVDG Ø8-25mm

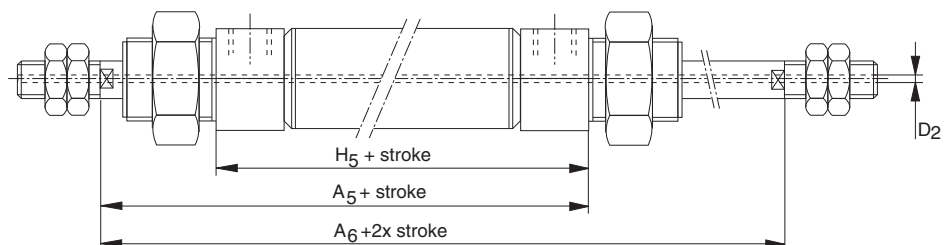

See ROV and ROVD drawings for balance of dimensions

# ROV Oval Bore Cylinder



## Dimensional Data

Bore Ø	A	A <sub>5</sub> + stroke	A <sub>6</sub> +2 x stroke	B	B <sub>2</sub>	B <sub>3</sub>	C	D	Ø D <sub>1</sub>	D <sub>2</sub>	E	F hex
8	0.51 13	2.40 61	3.03 77	M12 x 1.25	0.56 11.8	0.33 8.3	0.59 15	M4	0.16 4	0.04 1	0.47 12	14
10	0.51 13	2.40 61	3.03 77	7/16 • 20 M12 x 1.25	0.56 14.3	0.41 10.3	0.59 15	6 • 32 M4	0.16 4	0.04 1	0.47 12	0.55 14
12	0.67 17	2.68 68	3.54 90	M16 x 1.5	0.68 17.3	0.48 12.3	0.83 21	M6	0.24 6	0.05 1.2	0.63 16	0.79 20
16	0.67 17	2.95 75	3.82 97	5/8 • 18 M16 x 1.5	0.78 19.8	0.56 14.3	0.83 21	10 • 32 M6	0.24 6	0.05 1.2	0.63 16	0.79 20
20	0.79 20	3.58 91	4.53 115	M22 x 1.5	1.00 25.5	0.81 20.5	0.94 24	M8	0.30 8	0.13 3.2	0.79 20	1.06 27
25	0.87 22	3.94 100	5.04 128	7/8 • 14 M22 x 1.5	1.04 26.5	0.89 22.5	1.10 28	3/8 • 24 M10 x 1.25	0.39 10	0.13 3.2	0.87 22	1.06 27
Bore Ø	G	H + stroke	H <sub>5</sub> + stroke	L + stroke	M	N	O <sub>H9</sub>	R <sub>d13</sub>	SW	SW1	SW2	
8	M5	1.89 48	1.77 45	3.39 86	0.24 6	0.24 6	0.16 4	0.30 8	--	19	7	
10	10 • 32 M5	1.89 48	1.77 45	3.39 86	0.24 6	0.24 6	0.16 4	0.3 8	--	19	7	
12	M5	2.09 53	1.81 46	4.21 102	0.24 6	0.35 9	0.24 6	0.47 12	5	23	10	
16	10 • 32 M5	2.36 60	2.09 53	4.21 107	0.24 6	0.35 9	0.24 6	0.47 12	5	23	10	
20	G1/8	2.80 71	2.64 67	5.20 132	0.30 8	0.47 12	0.31 8	0.63 16	7	32	13	
25	1/8 NPTF G1/8	2.99 76	2.83 72	5.63 143	0.31 8	0.47 12	0.31 8	0.63 16	9	32	17	